

## DTMF decoder kit with relay output, opto coupled input & Morse transpond.

Our DTMF Opto decoder kit has one relay output offering clean contacts, and one Opto coupled input offering complete isolation from the circuit being monitored.

The output can be switched on/off remotely with or without a 4 digit security code. The decoder also has a TX keying output to key a transmitter for transponding a Morse confirmation. An audio output is included for the Morse audio tones. The PCB has been designed to allow 3 input configurations - unbalanced audio, an Electret microphone or balance audio to be connected.

The Opto input can be interrogated and a Morse confirmation received confirming the current state (on or off).

To turn the Output on/off send the decoder its ID followed by 0 and \* for ON or # for OFF e.g. 12340\* turns the output on and 12340# turns the output off.

To toggle the output send e.g. 12340A and the state of the output will be changed to the opposite of its previous state - the Morse transpond will be confirmation of the new state. To pulse the output send e.g. 12340B and the output will turn on for 0.5 seconds - the Morse transpond will be 0P.

You can use 9 for A and 8 for B with 12 key DTMF pad.

For confirmation of the switching of the output the decoder will key a Transmitter and respond in Morse code. Turning on the output will respond as 0 ON in Morse, and turning off the output will respond as 0 OFF. There is a 2 second transpond delay followed by a 400ms link establishment delay to allow for CTCSS (if used).

To interrogate the current state of the Opto 1input send the ID followed by 1\* e.g. 12341\* and the decoder will transpond in Morse 1 OFF or 1 ON depending on the input state.

To interrogate the state of the output without changing it send the ID followed by 2\* e.g. 12342\*

The 4 digit security ID can be changed by simply fitting a jumper to the middle 2 pins of CN3, powering up the decoder and sending it a new 4 digit ID with DTMF, then remove power, remove jumper and power-up and the new ID is set. If no ID is required then simply program the ID as 0000 and on next power-up no ID will be needed and e.g. 0\* will turn on the output.

## DTMF Opto



All parts shown in the assembled photo are included as well as some extras resistors for alternative input configuration.

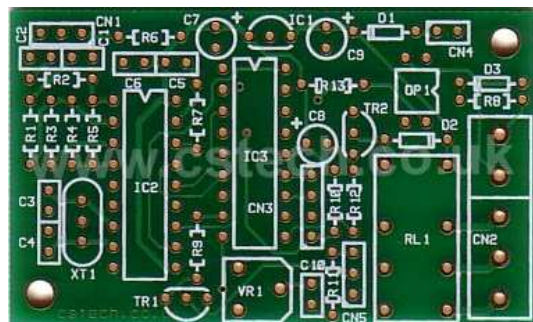

A circuit diagram is on the last page of this document.

A PDF data sheet for the HT9170B maybe viewed at:-

[cstech.co.uk/ht9170.pdf](http://cstech.co.uk/ht9170.pdf)

There is also the ability to turn off the Morse transpond. When setting the 4 digit identity, add a fifth digit as 9 and the Morse transpond will be turned off. Any other character in the fifth position turns the Morse transpond on. When supplied the identity is supplied as 1234 and the fifth digit is set as 0. You do not need to program the fifth digit if transpond is desired, the fifth digit is not used as part of the identity.

The PCB is a high quality Gold Plated double sided PTH (plated through hole) 1.6mm FR4 (Fibreglass) board 64 x 38mm in size.

CN3 can also be used for in-circuit re-programming of the PIC with your own code.

There are many sources of DTMF, tone pads, two-way radio microphone keypads, telephone systems, and even your mobile phone's keypad tones.

As an example if using as a DTMF code lock, use a mobile phone's keypad tones and use the microphone option for pick up.

#### DTMF Opto Decoder Parts List

|                |                                   |
|----------------|-----------------------------------|
| IC1            | 78L05                             |
| IC2            | HT9170B                           |
| IC3            | PIC16F627A (programmed)           |
| OP1            | FOD617D                           |
| TR1, 2         | BC184L                            |
| D1, 2, 3       | 1N4148                            |
| XT1            | 3.579MHz crystal                  |
| R1*            | 4K7                               |
| R2, 4          | not fitted                        |
| R3*            | 270K                              |
| R5             | wire link                         |
| R6*            | 1K                                |
| R7             | 330K                              |
| R8, 12         | 2K2                               |
| R9, 10, 11, 13 | 10K                               |
| VR1            | 10K variable                      |
| C1, 5, 6, 10   | 100nF (marked 104)                |
| C2             | not fitted                        |
| C3, 4          | 22pf                              |
| C7, 8, 9       | 1uF (marked 105) observe polarity |
| CN1, 5         | 3 pins                            |
| CN2            | 5 way terminal block (2 + 3 way)  |
| CN4            | 2 Pins                            |
| CN3            | 4 Pins                            |
| RL1            | BT47 style 12V relay              |

Also supplied:-

DTMF Opto PCB Issue A

1 x 0.1" jumper link

2 x 10K for alternative input configuration

#### Applications include:-

1, DTMF remote control with relay O/P over radio or mobile phone, with input interrogation.

2, DTMF code lock etc.

3, Repeater remote shutdown.

4, Simple DTMF selcall.

#### Specification

Supply Voltage: 11 to 14V DC

Supply Current: ~10 to 40mA (relay Off / On)

Relay Contacts: 24V DC 1 Amp Max.

Opto input: 5 to 24V DC (reverse protected)

Audio input: See notes below

\*Note:-

Only fit R6 if using an Electret microphone as input.

Only fit R1 & R3 as 4K7 & 270K for use with a microphone, otherwise fit R1 & R3 as 10K or calculate a custom input configuration from HT9170 datasheet.

### DTMF Opto Decoder application notes follow.

There are 3 input configurations for our DTMF decoder, Electret microphone, un-balance and balanced, the 3 options are shown below in the circuit extracts. The HT9170 DTMF decoder chip has a wide input signal range from approx. 27mV to 775mV, but as it contains an op-amp at it's input and the op-amp gain can be altered using different resistor values, many combinations can be achieved.

Please see notes below.

The Electret microphone input version provides power to a microphone insert via R6 (1K) and using R1 at 4K7 and R3 at 270K to set the decoder chip's input op-amp gain to x57 the sensitivity allows pick-up from a DTMF tone pad at a couple of inches. A speaker phone, two-way radio speaker or the keypad tones from a mobile can be picked up 6 to 12 inches away.

We do not recommend increasing the input gain any higher.

Connect the microphone between pins 1 and 2 (2 = GND).

Resistors are provided in the kit for this option.

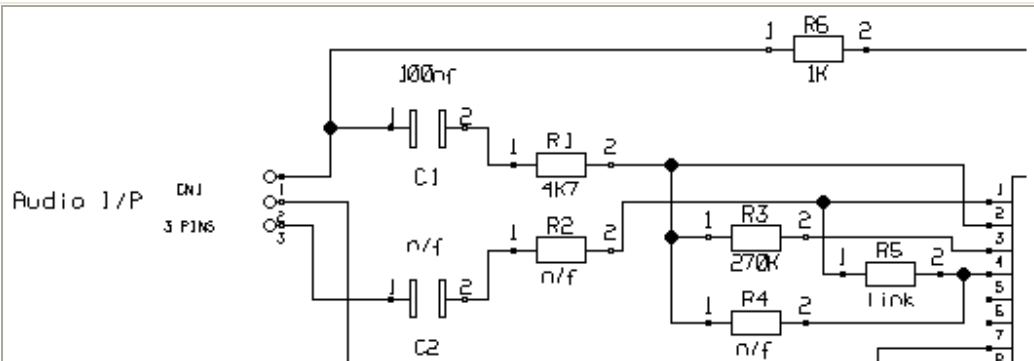

This example offers an un-balanced audio input, using 10K resistors for R1 and R3 sets the decoder chip's input gain at x1 and gives an input impedance around 10K, R6 is omitted and this configuration can be fed directly from say the Packet modem RX audio output of a Ham radio.

If it is desired to change the input gain then increase R3 for higher gain and decrease R3 for lower gain.

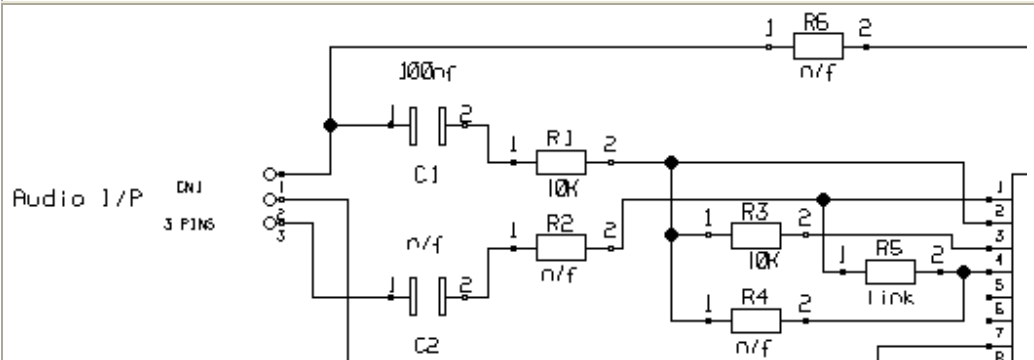



R1 & R3 set input op-amp gain  
 C2, R2, R4 & R5 are for balanced input  
 R6 = mic power feed option

